

ATHENS-CLARKE COUNTY BUILDING INSPECTION DEPARTMENT
120 W. DOUGHERTY STREET, ATHENS, GA 30601 - (706) 613-3520

BUILDING PERMIT SUPPLEMENT FOR INSTALLATION
OF MASONRY, FACTORY BUILT FIREPLACES AND
FACTORY BUILT FIREPLACE STOVES

PERMIT FEE: \$80.00 PERMIT NUMBER: _____

APPROVED BY: _____ **DATE:** _____

ADDRESS OF INSTALLATION: _____

OWNER: _____

CONTRACTOR/INSTALLER: _____

SIGNATURE _____ PRINT NAME _____

ADDRESS: _____

PHONE: _____

BUILDING USE: RESIDENTIAL _____ COMMERCIAL _____ INDUSTRIAL _____

TYPE OF HEATING EQUIPMENT:

MASONRY FIREPLACE: _____ MODEL NUMBER: _____

WOOD STOVE OR INSERT: _____ MFR.: _____

PREMANUFACTURED FIREPLACE: _____ U.L. LISTING: _____

TYPE VENTING EQUIPMENT:

SINGLE WALL: _____ VENT SIZE: _____

TRIPLE WALL METAL: _____ U.L. LISTING: _____

ASBESTOS INSULATED: _____

MASONRY: _____

OTHER: _____

EQUIPMENT IS TO BE INSTALLED ACCORDING TO MANUFACTURERS' INSTRUCTIONS. IN ABSENCE OF MANUFACTURERS' INSTRUCTIONS, SEE THE ATTACHED SHEET OF THIS APPLICATION FOR PROPER CLEARANCES.

THIS PERMIT IS VALID FOR SIX MONTHS UNLESS EXTENDED BY THE INSPECTION DEPARTMENT. ALL IS TO CONFORM TO THE STANDARD MECHANICAL CODE, STANDARD GAS CODE, STANDARD BUILDING CODE, AND THE NATIONAL ELECTRICAL CODE.

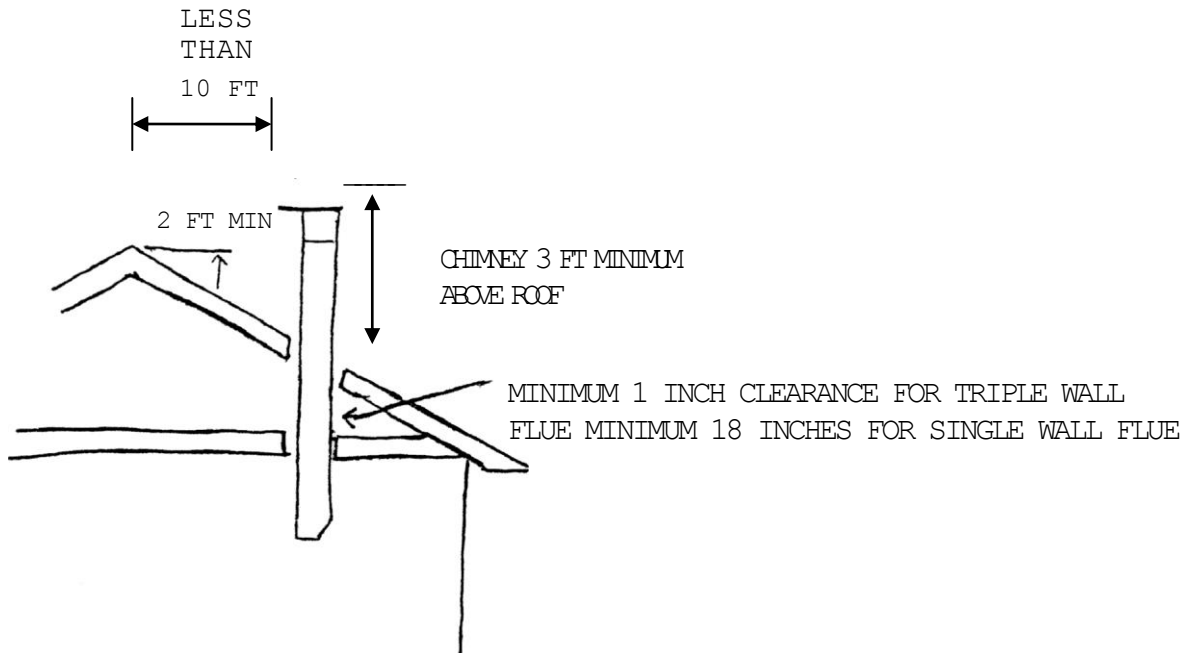
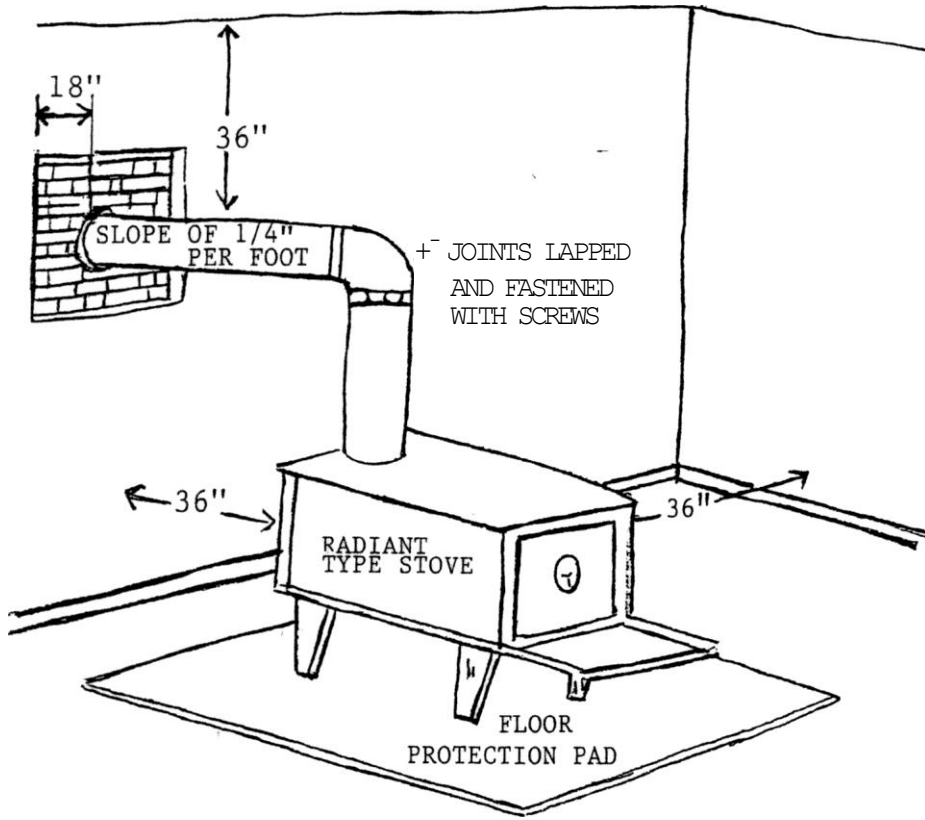

ABOVE CLEARANCE REQUIREMENTS FROM COMBUSTIBLES MAY BE REDUCED WITH THE INSTALLATION OF PROPER MATERIALS AS APPROVED BY THE INSPECTOR