

COVER BACK

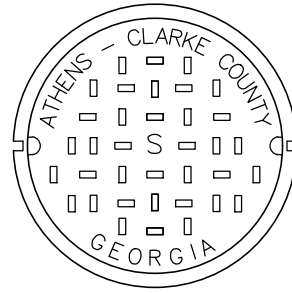

COVER FACE

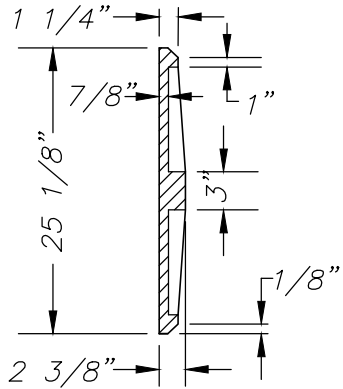

COVER SECTION

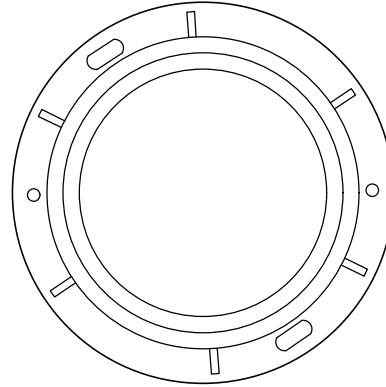

FRAME PLAN

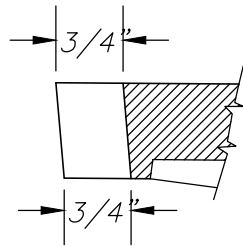

(2) TYPE ONE PICKSLOTS

PICKSLOT DETAIL

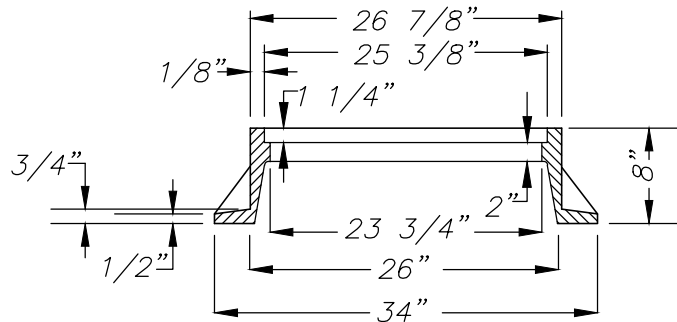

FRAME SECTION

Frame and Cover Manhole Detail

NTS

MH-1

Standard Specification and Detail for:

Frame and Cover Manhole Detail

GMD: NA	County: Athens-Clarke	State: Georgia	Date: August, 2019
---------	-----------------------	----------------	--------------------

Drawn by: KFM

Approved by: GJ

Scale: AS-SHOWN

The Unified Government of Athens-Clarke County

Department of Public Utilities

124 E Hancock Ave

Athens, Georgia 30601

Fax: 706-613-3198

Voice: 706-613-3490

